

ATTRACTION P&P

WSI Refrigeration

PLUG & PLAY

SERVE OVER | SELF - SERVICE CABINETS



RETAIL SYSTEM | PRODUCT





ATTRACTION P&P

ATTRACTION P&P is a plug-in refrigerated counter with condensation unit at the bottom of the counter, which is easily accessible. With large selection of configurations, which ensure that counter, can satisfy even the highest demands. **Flat or curved front glass** is designed for maximal transparency and perfect display area.

ATTRACTION P&P counters are designed with high quality **bottom tilting opening front glass for easier cleaning and maintenance**. It is available as serve-over and **self-service**, with wide range of accessories and variable base decoration options.

Due to implemented natural refrigerant R290 ATTRACTION P&P is operating quietly and leaves a smaller footprint on the environment.

Temperature class: M1 / M2

Refrigerant: R290

STANDARD EQUIPMENT

- Interior display deck completely in stainless steel
- Integrated LED lightning (colour adapted to food group)
- Canopy LED lightning (colour adapted to food group)
- Stainless steel working table
- High efficiency EC fans

CUSTOMIZATION

- Controller options (Danfoss, Carel, Dixell Wurm, Eliwell)
- Stainless steel bumper
- Flat or curved glass design
- Self-Service version
- Heated version (Hot sections or Bain-marie)
- Endwalls/Intermediate – panoramic, mirrored
- A variety of interior / exterior colour options

Accessories: scale and cutting board, knife holder, paper holder, stepped decks, glass dividers , etc.

REFRIGERATED OR HEATED COUNTER

- Unified design with clean geometric lines
- Possibility of tailor made finishing - variety of materials and colours
- Integrated LED lighting - in colours adapted to products
- Front glass opening bottom up
- Available in curved glass version
- Evaporator at the back – empty base allows easy cleaning and better cold air circulation
- Stainless steel base - longer lifetime
- Wide range of accessories
- Available in self-service, hot section, Pastry and Pastry Hot version



ATTRACTION P&P Flat

ATTRACTION 112 Flat P&P

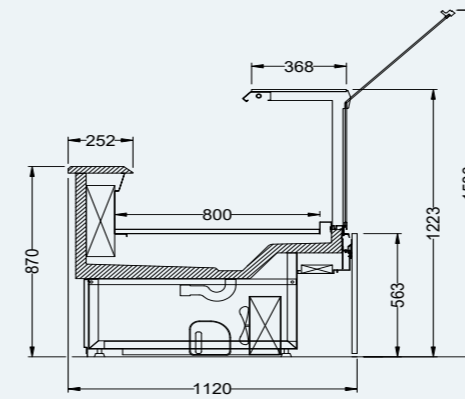

ATTRACTION 122 Flat P&P

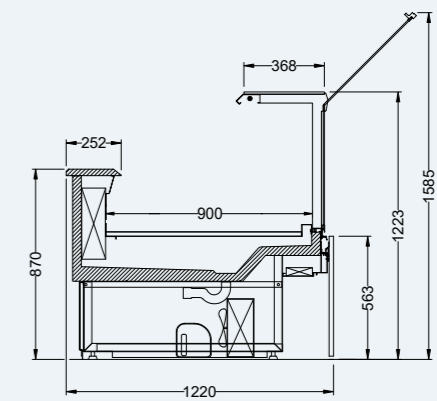

ATTRACTION P&P Curved

ATTRACTION 112 Curved P&P

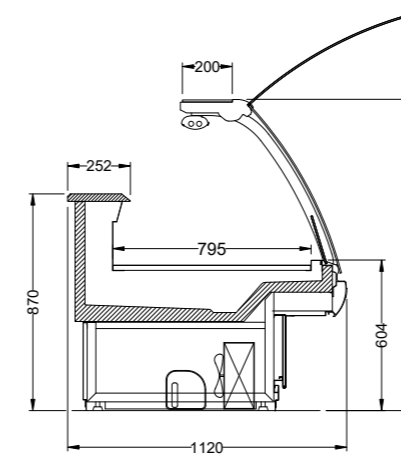

ATTRACTION 122 Curved P&P

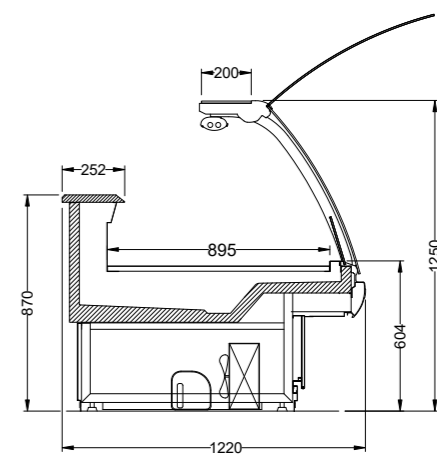

Design	Height (mm)	Vizual display (mm)	Depth (mm)	Lenght (mm)						Temperature class*	
				937	1250	1875	2500	3125	3750	M1	M2
Flat	1223	800	1120	✓	✓	✓	✓	✓	✓	✓	✓
		900	1220	✓	✓	✓	✓	✓	✓		
Curved	1250	800	1120	✓	✓	✓	✓	✓	✓	✓	✓
		900	1220	✓	✓	✓	✓	✓	✓		



ATTRACTION P&P
Self - Service

ATTRACTION 112 Flat Self P&P

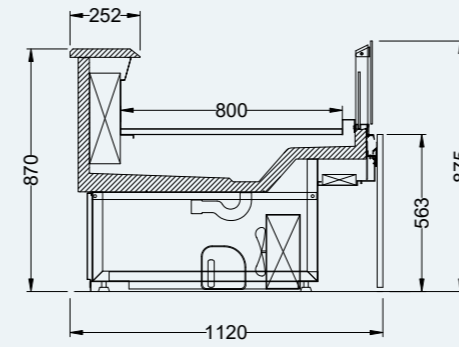

ATTRACTION 122 Flat Self P&P

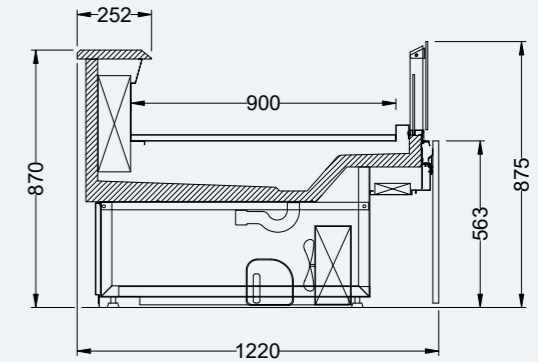

ATTRACTION 112 Curved Self P&P

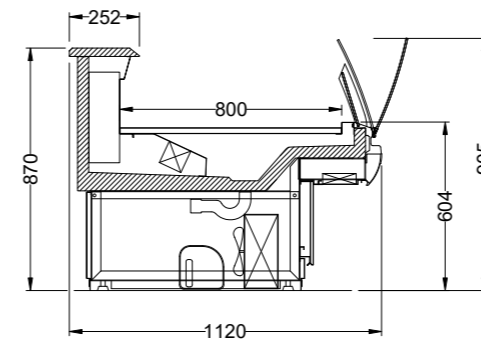

ATTRACTION 122 Curved Self P&P

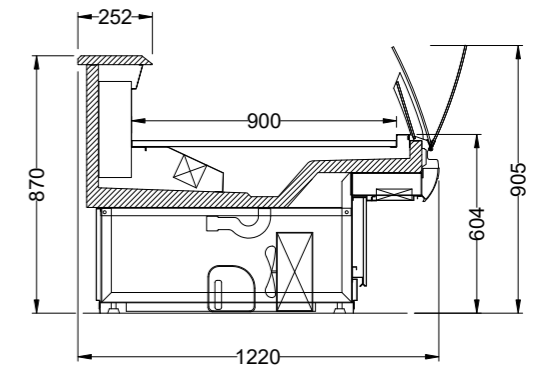

Design	Height (mm)	Vizual display (mm)	Depth (mm)	Lenght (mm)						Temperature class*	
				937	1250	1875	2500	3125	3750	M1	M2
Flat	1223	800	1120	✓	✓	✓	✓	✓	✓	✓	✓
		900	1220	✓	✓	✓	✓	✓	✓		
Curved	1250	800	1120	✓	✓	✓	✓	✓	✓	✓	✓
		900	1220	✓	✓	✓	✓	✓	✓		



ATTRACTION SV P&P

ATTRACTION SV P&P is a semi-vertical plug-in refrigerated cabinet with condensation unit at the bottom of the cabinet, which is easily accessible. This cabinet is suitable for **self-service sale of prepacked products such as sushi, meat, delicatessen, dairy products.**

The form of **ATTRACTION SV P&P** provides an excellent functionality because of perfect match with serve over counter line. Containing 1 to 3 shelves, depending on height of the cabinet, which maximize the visibility of displayed products and place them within reach, providing a customer a pleasant purchasing experience and **stimulate impulse purchase, especially in strategic placed areas.**

Due to implemented natural refrigerant R290 **ATTRACTION SV P&P** is operating quietly and leaves a smaller footprint on the environment.

Temperature class
(refrigerated counter): M0 / M1 / M2

Refrigerant: R290

ATTRACTION SV P&P cabinets have same design as **ATTRACTION P&P** serve over counters which makes **a harmonized and engaging refrigeration line.**

STANDARD EQUIPMENT

- Manual night curtain
- Canopy LED lightning
- High efficiency EC fans

CUSTOMIZATION

- Controller options (Danfoss, Carel, Dixell, Wurm, Eliwell)
- Shelf LED lightning (adapted colour to food group)
- Stainless steel bumper
- SUSHI version
- Endwalls/Intermediate – blind, panoramic, mirrored
- A variety of interior / exterior colour options

Accessories: shelf dividers, plexi product stoppers, base grids, base dividers, etc.

HALF-HEIGHT CABINET

- Self-service counter, part of the Attraction serve-over line – less workforce presence
- Possibility of tailor made finishing – variety of materials and colours
- Possibility of back to back configuration
- Available in two depths and 3 height options – with 1, 2 or 3 shelves

ATTRACTION Pastry P&P

- Unified design with clean geometric lines
- Possibility of tailor made finishing - variety of materials and colours
- Integrated LED lighting - in colours adapted to products
- Front glass opening bottom up
- Rear sliding doors for easy product fill
- 2 rows of glass shelves
- Available as hot section - hot plates version
- Temperature class: M1 / M2/Hot section

ATTRACTION Pastry P&P is a refrigerated counter designed for display of cold and hot pastry products, juices etc. It has large selection of configurations, which ensure that counter, can satisfy even the highest demands. Cabinet is designed for maximal transparency and perfect display area.

ATTRACTION Pastry P&P



ATTRACTION Pastry P&P counters are designed with high quality bottom tilting opening front glass for easier cleaning and maintenance and rear sliding doors for easy product fill.

Due to implemented natural refrigerant R290 ATTRACTION P&P is operating quietly and leaves a smaller footprint on the environment.