

COMET

WSI Refrigeration

REMOTE

SEMI - VERTICAL CABINETS



RETAIL SYSTEM | PRODUCT





OPEN OR DOORS

- Semi vertical cabinet, available in SKY (S) and Horizon (H) design line
- Low front base – maximized total display area
- Evaporator at the back – empty base allows easy cleaning
- Stainless steel base – longer lifetime
- Soft closing hinged doors

COMET

COMET is a half-height vertical, modern designed refrigerated cabinet that ensures to meet the expectations for product display needs. COMET cabinets have same design as all other wall cabinets. COMET enables to obtain a perfect cooling performance and low height area requirements. It is an ideal solution for any type of sales area, it maximizes visibility of products and provides **reduction in energy consumption**.

COMET is suitable for the display and self-service sale of prepacked products such as meat, delicatessen, dairy products. COMET has also **WINE configuration** with mirror effect and special designed stainless steel shelves. It is ideal to display bottles at an optimal temperature. Evaporator position at the back of the cabinet allows **easy cleaning of the base tank**.

Refrigerant: R744 or HFC

CUSTOMIZATION

- Controller options (Danfoss, Carel, Dixell, Wurm, Eliwell)
- Number of shelves
- Horizontal LED lightning (colour adapted to food group)
- Sliding doors
- Complete stainless steel interior version
- WINE version
- Endwalls/Intermediate – blind, panoramic, mirrored
- A variety of interior / exterior colour options

Accessories: wine shelves, meat hangers, shelf dividers, shelf and base grids, plexi product stoppers, base grids, etc.

STANDARD EQUIPMENT

- Manual night curtain
- Canopy LED lightning

COMET S:

- Glass top canopy (COMET S Open)
- Full height frameless hinged glass doors
- High efficiency EC fans
- Electronic expansion valve
- Stainless steel bumper

COMET H:

- Metal top canopy - a variety of color options available (COMET H Open)
- Transparent hinged glass doors
- PVC bumper

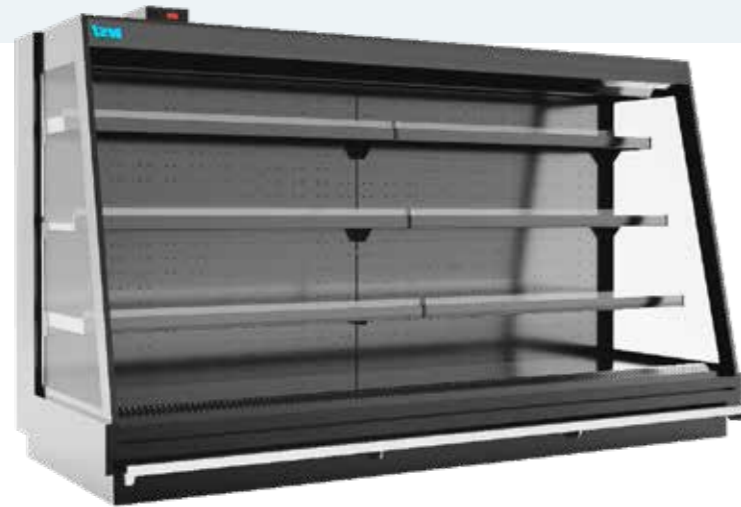

COMET Open

- Temperature class: M1 / M2 / H1

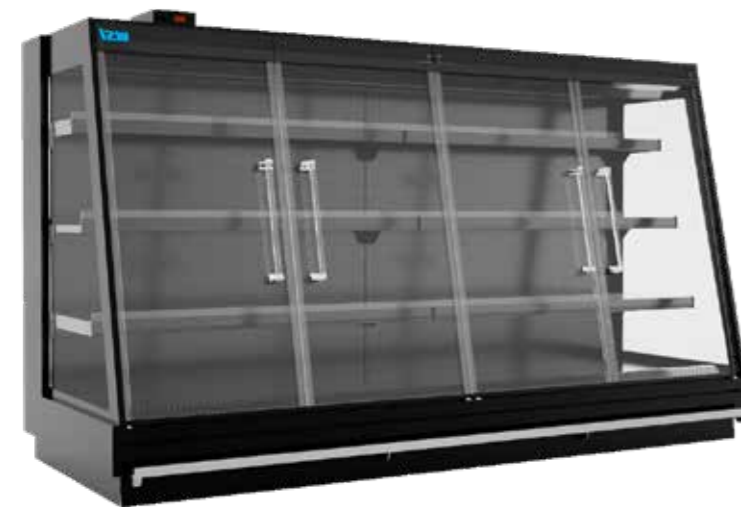

COMET Doors

- Temperature class: M0 / M1 / M2 / H1

COMET S Open

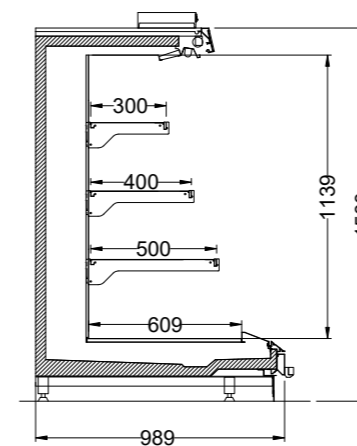

COMET H Open

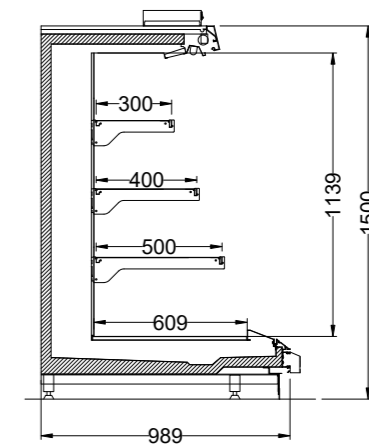

COMET S Doors

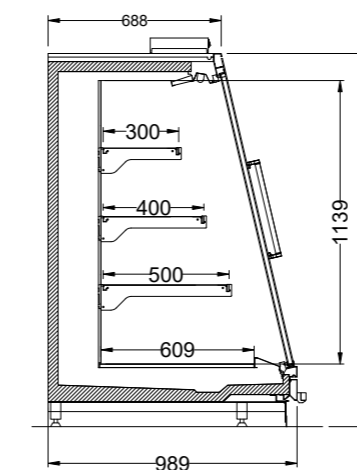

COMET H Doors

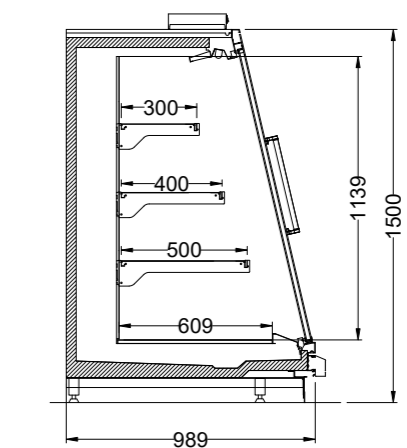

Design	Height (mm)	Vizual display (mm)	Depth (mm)	Shelf depth (mm)	Lenght (mm)				Head Piece Lenght (mm)	Temperature class*			
					1250	1875	2500	3750	2040	M0	M1	M2	H1
S	1500	1139	989	300-500	✓	✓	✓	✓	✓	Doors	Open Doors	Open Doors	Open Doors
H	1500	1139	989	300-500	✓	✓	✓	✓	✓				

COMET Headcase

- Ideal finish of back to back COMET cabinets
- Meeting the need for central layout positioning
- Ideal for large store formats
- Available in Open or Door version

COMET FV

- Perfect display of fruit or vegetables
- Preserving produce freshness through optimal air circulation
- Tilted shelves for maximum product visibility and easy accessibility

COMET Headcase

COMET FV

