

MOON

WSI Refrigeration

REMOTE
VERTICAL CABINETS



RETAIL SYSTEM | PRODUCT





MOON

Full-height vertical cabinet **MOON** is a remote cabinet with great price-quality correlation. MOON offers a great display area for dairy products, packed meat products, cold meats and fruit & vegetables and it is available with or without doors.

MOON has large selection of configuration. A **wide range of cabinet's depth** allows user great flexibility in selecting from 745 to 1074 mm with base shelf 800 mm. With the highest quality production techniques, MOON refrigerated cabinet provides **low energy consumption**, maximum visibility of the products and perfect cooling performance.

Refrigerant: R744 or HFC

STANDARD EQUIPMENT

- Manual night curtain
- Transparent glass doors
- Canopy LED lightning
- Thermal expansion valve
- Plastic bumper

MOON S:

- Glass top canopy (MOON S Open)
- Full height frameless glass doors
- High efficiency EC fans
- Stainless steel bumper

OPEN OR DOORS

- Wide range of cabinet's depth - adapts to any store concept
- Evaporator in the base - narrowest remote WSL cabinet with deepest shelving space for maximized TDA
- Galvanised metal base

CUSTOMIZATION

- Controller options (Danfoss, Carel, Dixell, Wurm, Eliwell)
- Number of shelves
- Horizontal or vertical LED lightning (colour adapted to food group)
- Electronic expansion valve
- High efficiency EC fans
- Stainless steel bumper
- Full height frameless glass doors
- Automatic night curtain
- Sliding doors
- Complete stainless steel interior version
- Endwalls/Intermediate - blind, panoramic, mirrored
- A variety of interior / exterior colour options

Accessories: wine shelves, meat hangers, front risers, vertical and shelf dividers, shelf and base grids, , etc.



MOON Open

- Metal top canopy - a variety color options available
- Temperature class: M1 / M2 / H1

MOON Narrow Open

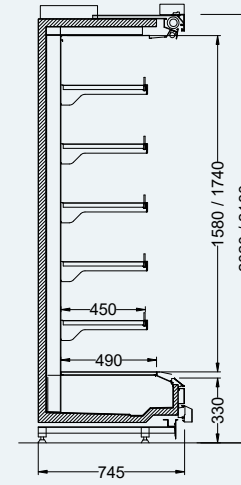

MOON 89 Open

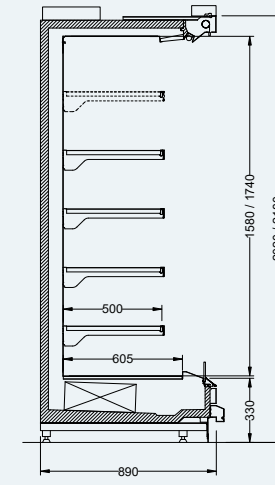

MOON 99 Open

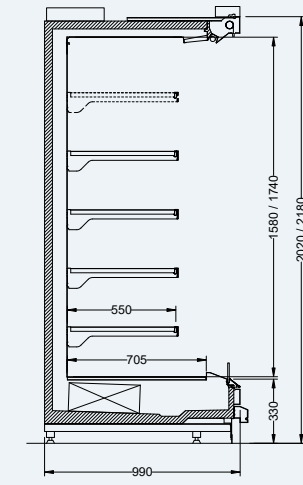

MOON 107 Open

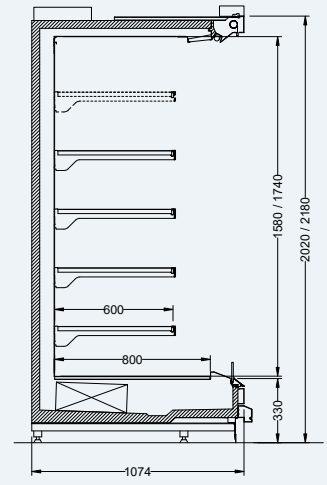

MOON Doors

- Transparent glass doors - high visibility of products
- Temperature class: M0 / M1 / M2 / H1

MOON Narrow Doors

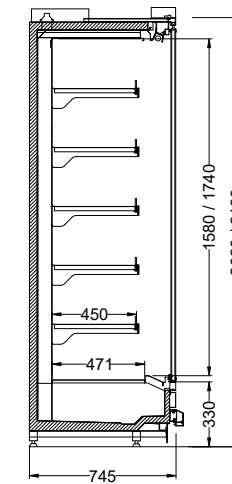

MOON 89 Doors

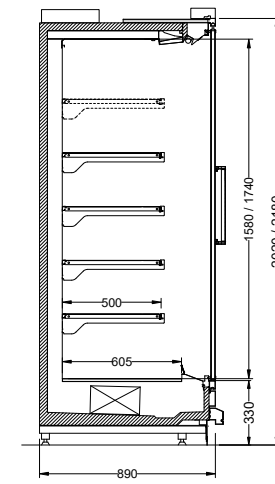

MOON 99 Doors

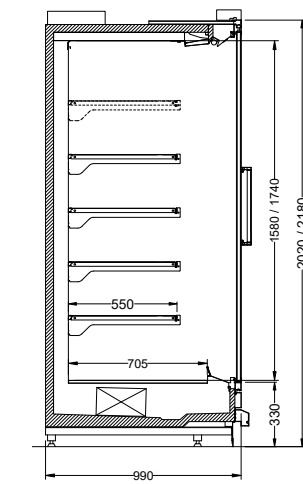

MOON 107 Doors

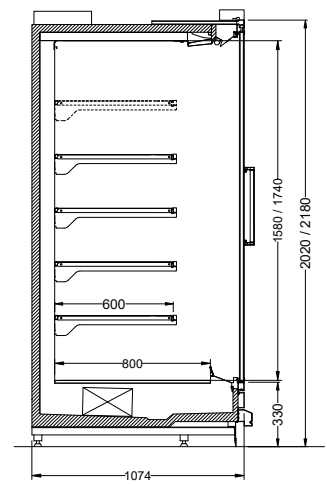

Height (mm)	Vizual display (mm)	Depth (mm)	Shelf depth (mm)	Lenght (mm)				Head Piece Lenght (mm)		Temperature class*			
				1250	1875	2500	3750	1955	2210	M0	M1	M2	H1
2020	1580	745	450	✓	✓	✓	✓	✓	✓	Doors	Open Doors	Open Doors	Open Doors
		889	500	✓	✓	✓	✓	✓	✓				
		989	550	✓	✓	✓	✓	✓	✓				
		1074	600	✓	✓	✓	✓	✓	✓				
2180	1740	745	450	✓	✓	✓	✓	✓	✓	Doors	Open Doors	Open Doors	Open Doors
		889	500	✓	✓	✓	✓	✓	✓				
		989	550	✓	✓	✓	✓	✓	✓				
		1074	600	✓	✓	✓	✓	✓	✓				

MOON Headcase

- Ideal finish of back to back MOON wall cabinets
- Meeting the need for central layout positioning
- Ideal for large store formats
- Available in Open or Door version

MOON Headcase



MOON FV

- Perfect display of fruit or vegetables
- Preserving produce freshness through optimal air circulation
- Tilted shelves for easy product accessibility
- Maximum visibility due to top mirror reflection

MOON FV

