



NEPTUN

NEPTUN COMBO



LOW TEMPERATURE CABINET

- Low temperature combined cabinet, available in SKY (S) and Horizon (H) design line
- Great capacity - displayed volume and floor space occupation
- Equipped with 2 evaporators top/bottom section for perfect freezing performance

Combined cabinet NEPTUN COMBO is combination of display and storage and it is ideal for selling frozen foods. Horizontal and vertical product presentation offers large volume capacity and easy access. Fully equipped with LED lighting, this cabinet offers maximum visibility of displayed products.

Additional dividers at the bottom part of the NEPTUN COMBO enable a transparent classification of goods. This combined cabinet is equipped with **electronic expansion valve and electronic controlled fans**. Both, vertical and horizontal part of the cabinet have

their own evaporator and advanced controller to ensure optimal operation and **maximum energy efficiency with low energy consumption**.

Temperature class: L1

Refrigerant: R744 or HFC

NEPTUN COMBO S cabinets have unified design, base and bumper height, aligned with SKY, NEPTUN S and COMET S, perfect for side by side placement, a **harmonized and engaging refrigeration line**.

CUSTOMIZATION

- Controller options (Danfoss, Carel, Dixell Wurm, Eliwell)
- High efficiency EC fans
- Electronic expansion valve
- Stainless steel bumper
- Endwalls - blind, panoramic, intermediate
- A variety of interior / exterior colour options

Accessories: plexi full height dividers, base and shelf dividers, base grids, etc.

STANDARD EQUIPMENT

- Vertical twin door frame LED lightning top section
- LED lighting in bottom tank
- Push lids closure system

NEPTUN COMBO S:

- Energy free doors
- Anti-fog coated doors
- Glass top canopy
- Stainless steel bumper
- High efficiency EC fans
- Electronic expansion valve

NEPTUN COMBO H:

- Triple glass high efficiency doors
- Metal top canopy
- Plastic bumper
- Thermal expansion valve



NEPTUN COMBO

NEPTUN COMBO 2031

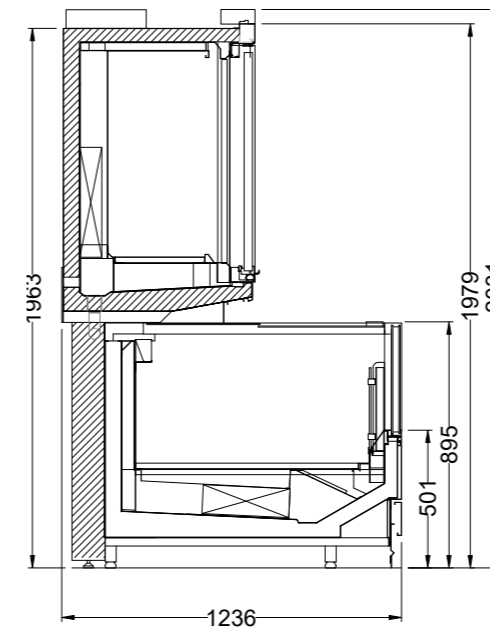

NEPTUN COMBO 2184

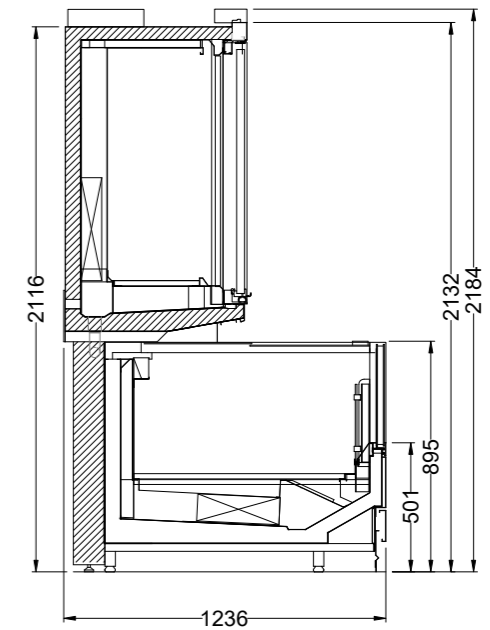

Height (mm)	VD VERTICAL (mm)	VD HORIZONTAL (mm)	Depth (mm)	Shelf depth vertical (mm)	Shelf depth horizontal (mm)	Length (mm)			Temperature class*	
						1875	2500	3750	M1	L1
2031	750	800	1236	350	350	✓	✓	✓	✓	✓
2184	900	800				✓	✓	✓	✓	✓





WE BRING FRESHNESS TO YOUR STORE

WSI Refrigeration

**Germany / Austria /
Switzerland**

- 📍 Germany / Austria / Switzerland
- ☎ +49 1525 54 29 168
- ✉ info.de@wsl-refrigeration.de

**Slovenia / BIH /
Montenegro**

- 📍 Sneberska cesta 111B
1260 Ljubljana-Polje
- ☎ +386 1 244 08 00
- ✉ info.si@wsl-refrigeration.com

Serbia

- 📍 Prva severna 8
22300 Stara Pazova
- ☎ +381 22 2155 701
- ✉ info.rs@wsl-refrigeration.com

Croatia

- 📍 Zagrebačka cesta 233
10000 Zagreb
- ☎ +385 1 3882 668
- ✉ info.hr@wsl-refrigeration.com

Greece

- 📍 Greece
- ☎ +30 6906 822402
- ✉ info.gr@wsl-refrigeration.com

West Europe

- 📍 West Europe
- ☎ +386 1 244 08 00
- ✉ info.si@wsl-refrigeration.com

Central and East Europe

- 📍 Central and East Europe
- ☎ +48 690 654 054
- ✉ info.cee@wsl-refrigeration.com

Balkan

- 📍 Balkan
- ☎ +381 64 64 10 439
- ✉ info.balkan@wsl-refrigeration.com

Middle East

- 📍 Middle East
- ☎ +381 64 64 41 850
- ✉ info.middleeast@wsl-refrigeration.com

America

- 📍 America
- ☎ +386 1 244 08 00
- ✉ info.si@wsl-refrigeration.com

Africa

- 📍 Africa
- ☎ +381 22 2155 701
- ✉ info.rs@wsl-refrigeration.com

Asia

- 📍 Asia
- ☎ +381 22 2155 701
- ✉ info.rs@wsl-refrigeration.com