



STAR P&P



STAR P&P is a promotional plug-in refrigerated island. Its design makes this island perfect for promotion sales of variety of foods and **stimulates impulse purchasing**. Transparent sides provide **maximum visibility** of products on display and enhance sales.

STAR P&P is operating quietly and it contains natural refrigerant R290, making it more environmentally friendly.

Temperature class: M1 / M2

Refrigerant: R290

STANDARD EQUIPMENT

- Panoramic endwalls
- Stainless steel bumper

CUSTOMIZATION

- Controller options (Danfoss, Carel, Dixell, Wurm, Eliwell)
- High efficiency EC fans
- Stainless steel interior
- A variety of interior / exterior colour options

STAR **Open** P&P

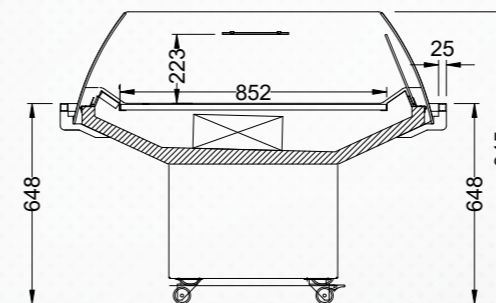

STAR **Sliding** P&P

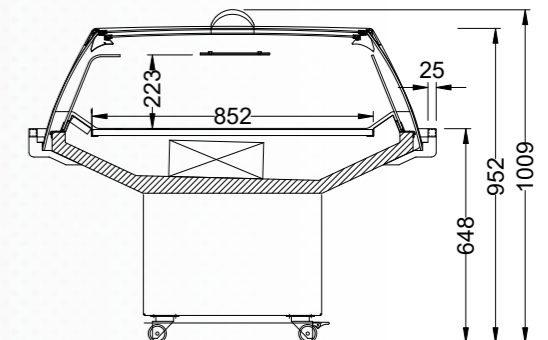

OPEN OR SLIDING GLASS COVER

- Designed for impulse buying and promotional sales
- Suitable for any store layout
- Multiplexable
- Moovable
- Variety of front mask decorations

Design	Height (mm)	Vizual display (mm)	Depth (mm)	Lenght (mm)		Temperature class*	
				938	1250	M1	M2
Open	945	852	1152	✓	✓	✓	✓
Door	1009	852	1152	✓	✓	✓	✓

STAR NARROW P&P



STAR NARROW P&P is a promotional plug and play refrigerated island, **suitable for smaller store formats** such as minimarkets or tighter store areas. Its design makes this island perfect for promotion sales of variety of foods and **stimulates impulse purchasing**. Transparent sides provide **maximum visibility** of products on display and enhance sales.

STAR NARROW P&P is operating quietly and it contains natural refrigerant R290, making it more environmentally friendly.

Temperature class: M1 / M2

Refrigerant: R290

STANDARD EQUIPMENT

- Panoramic endwalls
- Stainless steel bumper

CUSTOMIZATION

- Controller options (Danfoss, Carel, Dixell Wurm, Eliwell)
- High efficiency EC fans
- Stainless steel interior
- A variety of interior / exterior colour options

STAR NARROW **Open** P&P

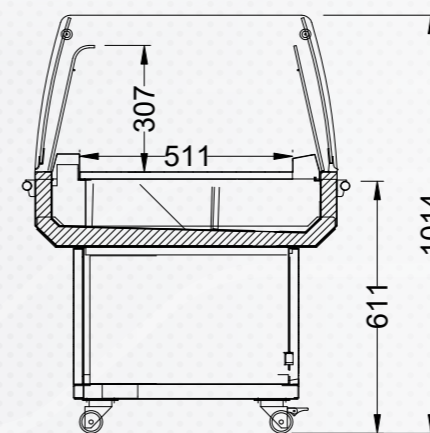

STAR NARROW **Sliding** P&P

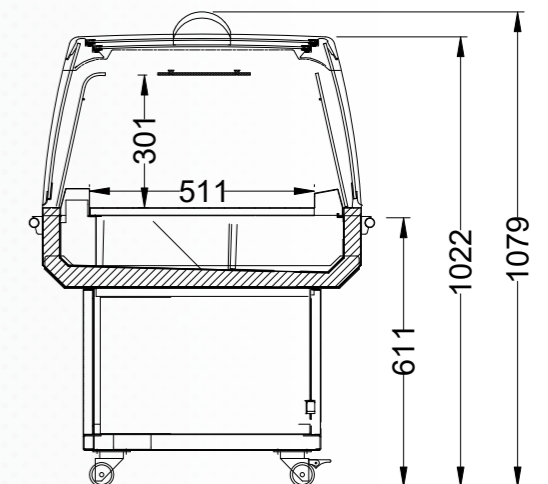

OPEN OR SLIDING GLASS COVER

- Designed for impulse buying and promotional sales
- Suitable for any store layout
- Multiplexable
- Moovable
- Variety of front mask decorations

Design	Height (mm)	Vizual display (mm)	Depth (mm)	Lenght (mm)		Temperature class*	
				938	1250	M1	M2
Open	1014	511	724	✓	✓	✓	✓
Door	1079	511	724	✓	✓	✓	✓

STAR FLAT P&P

STAR FLAT P&P is a promotional plug-in refrigerated island. Its design makes this island perfect for promotion sales of variety of foods and **stimulates impulse purchasing**. Transparent sides provide **maximum visibility** of products on display and enhance sales.

STAR P&P is operating quietly and it contains natural refrigerant R290, making it more environmentally friendly.

Temperature class: M1 / M2

Refrigerant: R290

STANDARD EQUIPMENT

- Panoramic endwalls
- Stainless steel bumper



CUSTOMIZATION

- Controller options (Danfoss, Carel, Dixell, Wurm, Eliwell)
- High efficiency EC fans
- Stainless steel interior
- A variety of interior / exterior colour options

OPEN OR SLIDING GLASS COVER

- Designed for impulse buying and promotional sales
- Suitable for any store layout
- Multiplexable
- Moovable
- Variety of front mask decorations

STAR FLAT P&P

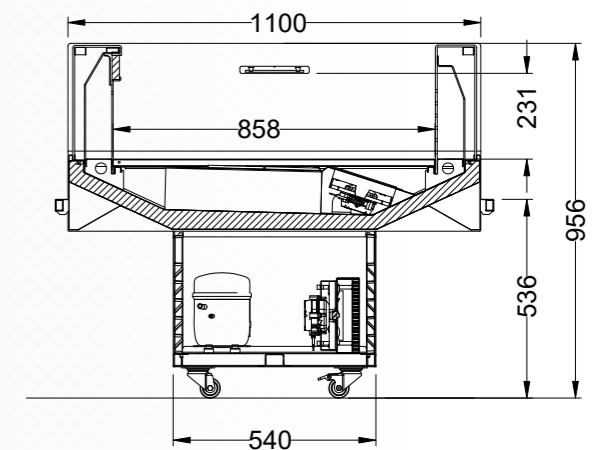

Design	Height (mm)	Vizual display (mm)	Depth (mm)	Lenght (mm)		Temperature class*	
				938	1250	M1	M2
Open	956	858	1100	✓	✓	✓	✓

STAR WS P&P

STAR WS P&P is a promotional plug and play refrigerated island with two shelves. With positive temperature range it is suitable for any type of cooled foods. The height of the two shelves provides a perfect highlighting of the promoted products and make **great first impressions**.

The premium look of the STAR WS P&P promotional cabinet is complement with transparent back panel, shelves and sides of the island, which enable **maximum all-around visibility** of the presented products and enhance impulse buying.

STAR WS P&P is operating quietly and it contains natural refrigerant R290, making it more environmentally friendly.

Temperature class: M1 / M2

Refrigerant: R290

STANDARD EQUIPMENT

- Panoramic endwalls
- Transparent back panel
- Two shelves
- Stainless steel bumper



CUSTOMIZATION

- Controller options (Danfoss, Carel, Dixell, Wurm, Eliwell)
- High efficiency EC fans
- Stainless steel interior
- A variety of interior / exterior colour options

STAR WITH SHELVES

- Designed for impulse buying and promotional sales
- Suitable for any store layout
- 2 shelves
- Movable
- Possibility of back to back configuration
- Transparent plexi back
- Variety of front mask decorations

STAR WS P&P

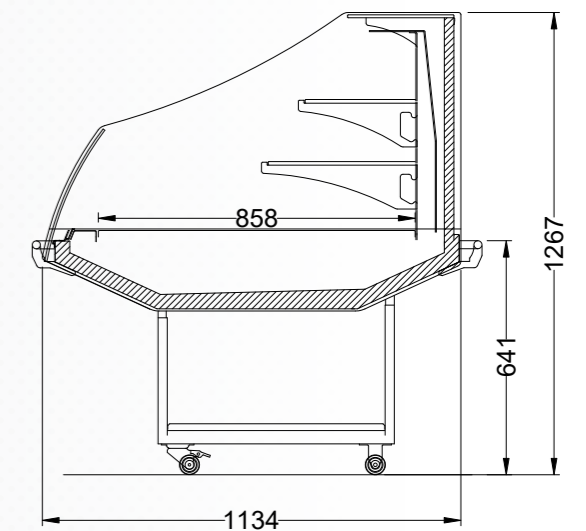

Height (mm)	Vizual display (mm)	Depth (mm)	Lenght (mm)		Temperature class*	
			938	1250	M1	M2
1267	858	1134	✓	✓	✓	✓





WE BRING FRESHNESS TO YOUR STORE

WSI Refrigeration

**Germany / Austria /
Switzerland**

- 📍 Germany / Austria /
Switzerland
- ☎ +49 1525 54 29 168
- ✉ info.de@wsl-refrigeration.de

**Slovenia / BIH /
Montenegro**

- 📍 Sneberska cesta 111B
1260 Ljubljana-Polje
- ☎ +386 1 244 08 00
- ✉ info.si@wsl-refrigeration.com

Serbia

- 📍 Prva severna 8
22300 Stara Pozova
- ☎ +381 22 2155 701
- ✉ info.rs@wsl-refrigeration.com

Croatia

- 📍 Zagrebačka cesta 233
10000 Zagreb
- ☎ +385 1 3882 668
- ✉ info.hr@wsl-refrigeration.com

Greece

- 📍 Greece
- ☎ +30 6906 822402
- ✉ info.gr@wsl-refrigeration.com

West Europe

- 📍 West Europe
- ☎ +386 1 244 08 00
- ✉ info.si@wsl-refrigeration.com

Central and East Europe

- 📍 Central and East Europe
- ☎ +48 690 654 054
- ✉ info.cee@wsl-refrigeration.com

Balkan

- 📍 Balkan
- ☎ +381 64 64 10 439
- ✉ info.balkan@wsl-refrigeration.com

Middle East

- 📍 Middle East
- ☎ +381 64 64 41 850
- ✉ info.middleeast@wsl-refrigeration.com

America

- 📍 America
- ☎ +386 1 244 08 00
- ✉ info.si@wsl-refrigeration.com

Africa

- 📍 Africa
- ☎ +381 22 2155 701
- ✉ info.rs@wsl-refrigeration.com

Asia

- 📍 Asia
- ☎ +381 22 2155 701
- ✉ info.rs@wsl-refrigeration.com