

GANIMED XL P&P

GANIMED XL TOP P&P

WSI Refrigeration

PLUG&PLAY

ISLANDS



RETAIL SYSTEM | PRODUCT





ISLAND OR WALL INSTALLATION

- Low temperature island cabinet
- Large storage space inside
- Modern squared design
- Sliding glass lids closure system
- Maintenance-free
- Easy product access
- Easy to clean

GANIMED XL P&P

GANIMED XL is a plug-in island cabinet with innovative design and environmentally friendly **no-frost** technology. This island is an optimal solution for displaying and storing frozen products, with easy access.

Modern squared design with glass cover increases visibility, which is additionally supported by LED lighting inside the cabinet. This No-Frost cabinet is equipped with **hot gas** automatic defrost system. By performing the defrosting process with hot gas in the system, it provides maximum efficiency. It is maintenance-free thanks to dust-repellent condenser system. Easy to clean due to the rounded inner corners and drain plug. It uses its energy economically without compromising the cooling rates in its chamber.

CUSTOMIZATION

- Variable speed compressor
- Second line bumpers
- Kickplate
- Positive temperature version
- Dual mode temperature regime

Accessories: Price Label, Grid separators (Set), Grid Baskets, Castors (4 Pcs), Island middle sheet price holder

GANIMED XL island can be installed next to the wall as well, which makes this island a perfect solution for any store layout. This island cabinet is also available in version with **positive** and **dual mode temperature** regime.

Temperature class: L1 / M1 / Dual mode

Refrigerant: R290

STANDARD EQUIPMENT

- LED lighting
- Front bumper
- No frost
- Curved-tempered-Low-E Glass
- Dust-free/Maintenance Free Condenser



GANIMED XL P&P 188

GANIMED XL P&P 188

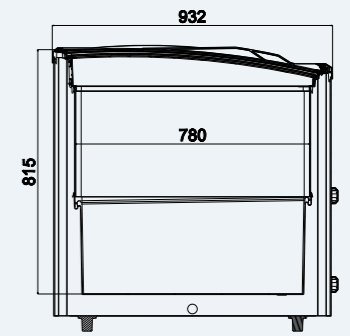
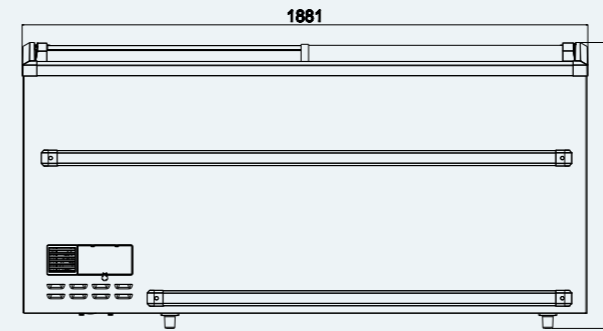

GANIMED XL P&P 212

GANIMED XL P&P 212

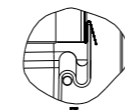
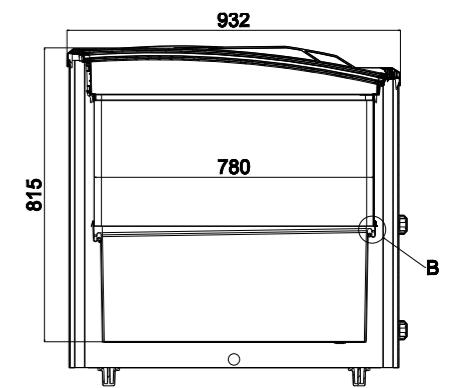
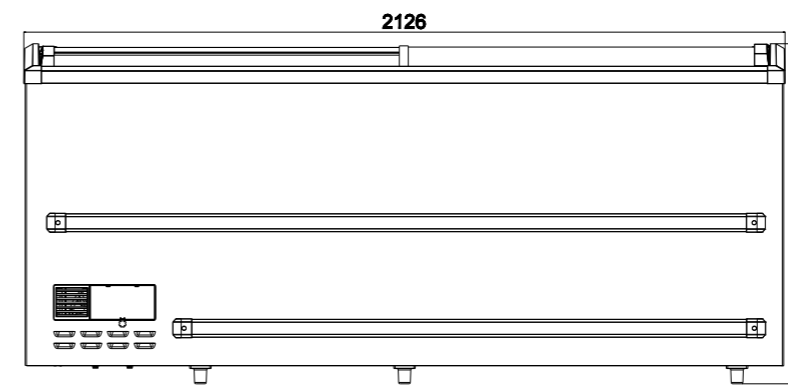

Height (mm)	Vizual display VERTICAL (mm)	Depth (mm)	Lenght (mm)		Temperature class*		
			1881	2126	M1	L1	Dual mode
950	780	922	✓	✓	✓	✓	✓



GANIMED XL P&P 250

GANIMED XL P&P 250

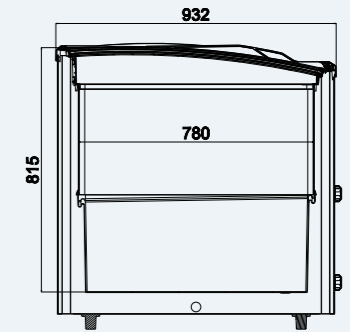
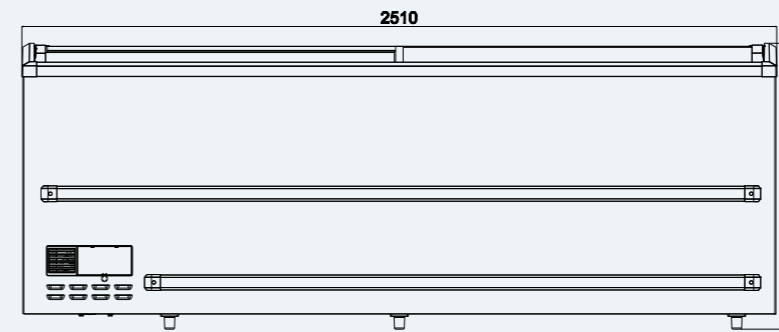

GANIMED XL P&P HEAD

GANIMED XL P&P HEAD

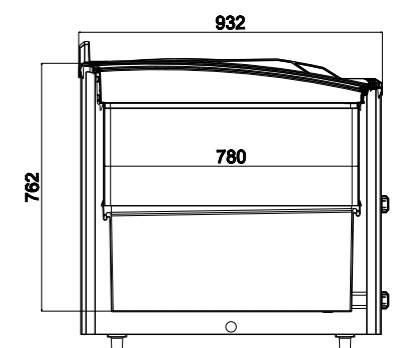
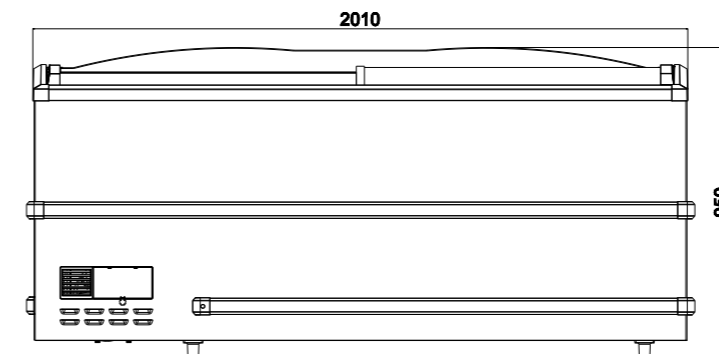

Height (mm)	Vizual display VERTICAL (mm)	Depth (mm)	Lenght (mm)		Temperature class*		
			2510	2010 (Head)	M1	L1	Dual mode
950	780	922	✓	✓	✓	✓	✓



ISLAND OR WALL INSTALLATION

- Low temperature island cabinet
- Large storage space inside
- Modern squared design
- Sliding glass lids closure system
- Maintenance-free
- Easy product access
- Easy to clean

GANIMED XL FG P&P

GANIMED XL is a plug&play island cabinet with innovative design and environmentally friendly **no-frost** technology. This island is an optimal solution for displaying and storing frozen products, with easy access.

Modern squared design with glass cover increases visibility, which is additionally supported by LED lighting inside the cabinet. This No-Frost cabinet is equipped with **hot gas** automatic defrost system. By performing the defrosting process with hot gas in the system, it provides maximum efficiency. It is maintenance-free due to dust-repellent condenser system. Easy to clean thanks to rounded inner corners and drain plug. It uses its energy economically without compromising the cooling rates of the foods and beverages placed in its chamber.

CUSTOMIZATION

- Variable speed compressor
- Second line bumpers
- Kickplate
- Positive temperature version
- Dual mode temperature regime

Accessories: Price Label, Grid separators (Set), Grid Baskets, Castors (4 Pcs), Island middle sheet price holder

GANIMED FG XL panoramic glass front wall provide a better view of the merchandise and enhanced presentation of the products.

Temperature class: L1 / M1/ Dual mode

Refrigerant: R290

STANDARD EQUIPMENT

- **Panoramic front glass wall (FG)**
- LED lighting
- Front bumper
- No frost
- Curved-tempered-Low-E Glass
- Dust-free/Maintenance Free Condenser



GANIMED XL FG P&P 188

GANIMED XL P&P 188

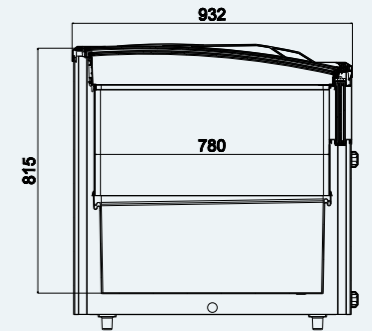
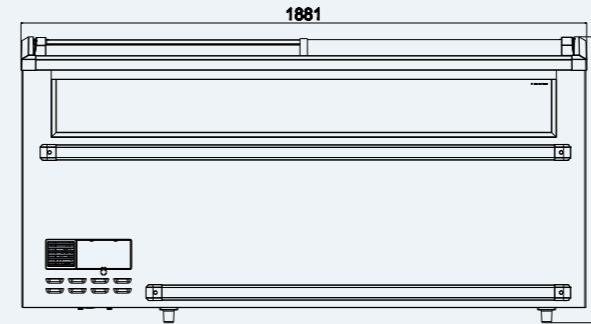

GANIMED XL FG P&P 212

GANIMED XL P&P 212

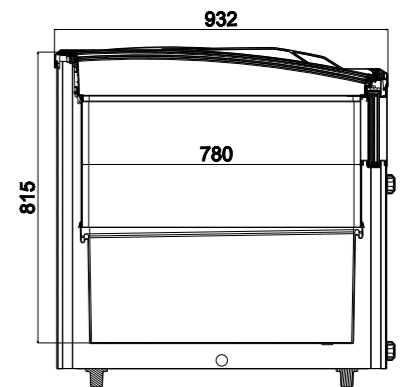
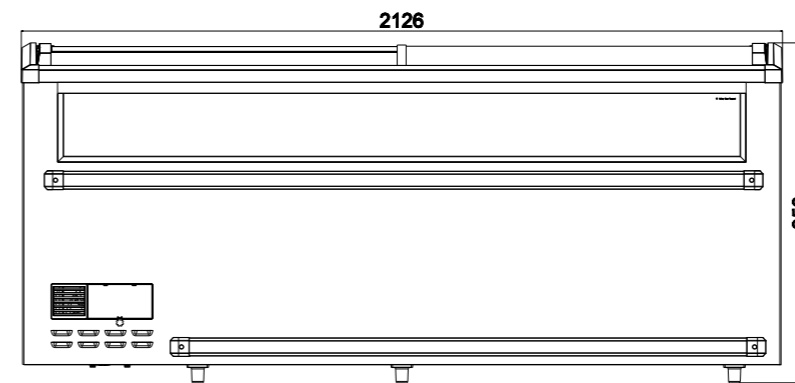

Height (mm)	Vizual display VERTICAL (mm)	Depth (mm)	Lenght (mm)		Temperature class*		
			1881	2126	M1	L1	Dual mode
950	780	922	✓	✓	✓	✓	✓

GANIMED XL P&P 250



GANIMED XL FG P&P 250

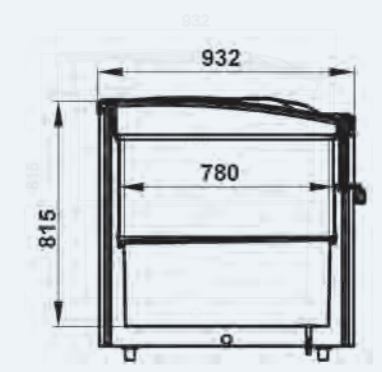
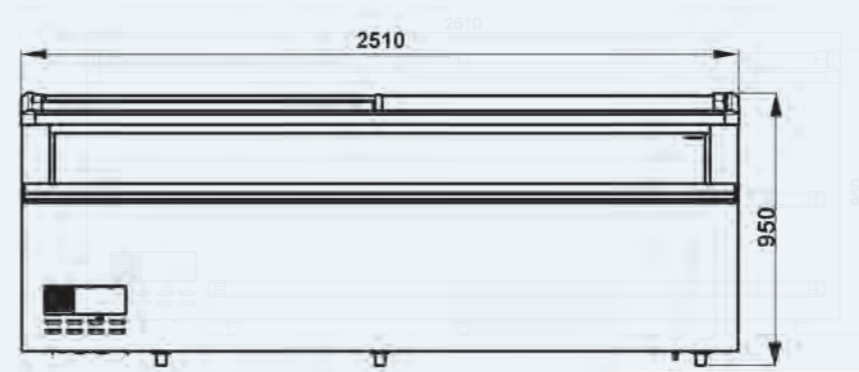

GANIMED XL P&P HEAD



GANIMED XL FG P&P HEAD

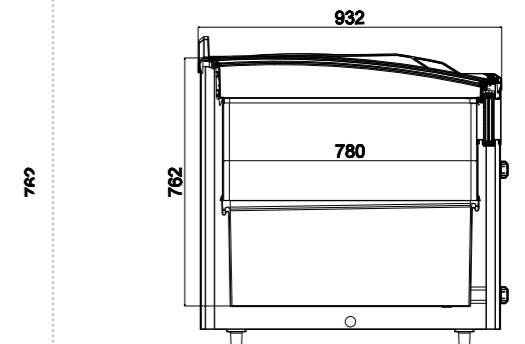
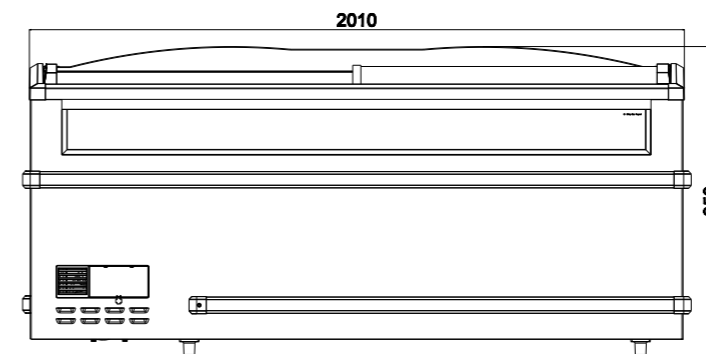

Height (mm)	Vizual display VERTICAL (mm)	Depth (mm)	Lenght (mm)		Temperature class*		
			2510	2010 (Head)	M1	L1	Dual mode
950	780	922	✓	✓	✓	✓	✓



GANIMED XL COMBO

WALL OR ISLAND INSTALLATION

- Low temperature island cabinet
- Large storage space inside
- Modern squared design
- Self Closing Door
- Easy product access

GANIMED XL TOP P&P

GANIMED TOP XL is a horizontal plug-in cabinet for displaying and storing frozen products with easy access. Fully equipped with LED Lighting, this cabinet offers maximum visibility of displayed products. It has its own evaporator and controller to ensure optimal operation and maximum energy efficiency.

GANIMED XL TOP plug-in cabinet can be perfectly combined with island Ganimed XL 212/250 or Ganimed XL FG 212/250. Ganimed island and Ganimed top incorporated create a combined

cabinet **Ganimed XL COMBO**, offering space optimization and a large volume capacity. A combined cabinet integrates excellent visibility of a vertical cabinet, with easy product picking typical of an island.

Temperature class: L1 / Dual mode

Refrigerant: R290

STANDARD EQUIPMENT

- Frameless triple glass doors
- Horizontal LED lighting
- 3 rows of shelves
- Ventilated colling system
- Dust-free wired condenser

CUSTOMIZATION

- Variable speed compressor
- Extra shelves
- Door Lighting
- Vertical LED lighting
- Dual Mode Regime (2 working temperatures)
- Waterloo HE integration: HYBRID SYSTEM
- Price label tag for shelves



GANIMED XL TOP 2120

GANIMED XL TOP 2120:

- Vertical triple door
- 3+3+3 Shelves PE coated
- Hot gas defrost
- Dust-free Condenser
- Horizontal LED lighting
- Variable speed compressor

GANIMED XL TOP 2500:

- Vertical triple door
- 3+3+3+3 Shelves PE coated
- Hot gas defrost
- Dust-free Condenser
- Horizontal LED lighting
- Variable speed compressor



GANIMED XL TOP 2500

GANIMED XL TOP P&P

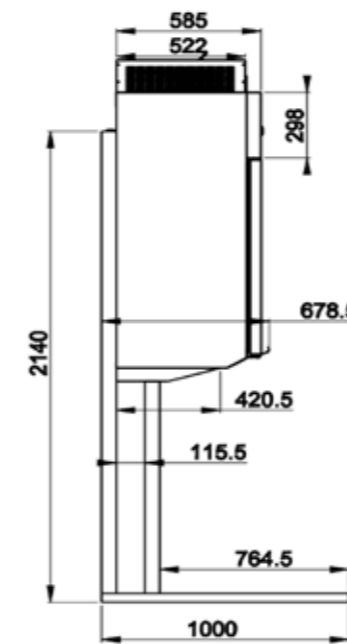

GANIMED XL TOP P&P side view

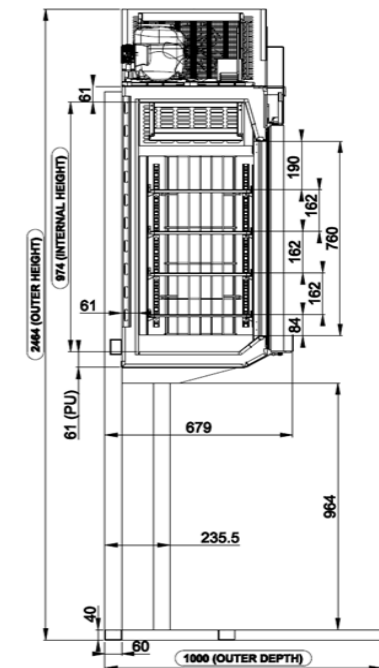

	Height (mm)	Vizual display VERTICAL (mm)	Depth (mm)	Shelf depth (mm)	Lenght (mm)		Temperature class*	
					2126	2510	L1	Dual mode
with legs	2462	760	1000	500	✓	✓	✓	✓
without legs	1398	760	576	500	✓	✓	✓	✓





WE BRING FRESHNESS TO YOUR STORE

WSI Refrigeration

**Germany / Austria /
Switzerland**

- 📍 Germany / Austria /
Switzerland
- ☎ +49 1525 54 29 168
- ✉ info.de@wsl-refrigeration.com

**Slovenia / BIH /
Montenegro**

- 📍 Sneberska cesta 111B
1260 Ljubljana-Polje
- ☎ +386 1 244 08 00
- ✉ info.si@wsl-refrigeration.com

Serbia

- 📍 Prva severna 8
22300 Stara Pozova
- ☎ +381 22 2155 701
- ✉ info.rs@wsl-refrigeration.com

Croatia

- 📍 Zagrebačka cesta 233
10000 Zagreb
- ☎ +385 1 3882 668
- ✉ info.hr@wsl-refrigeration.com

Greece

- 📍 Greece
- ☎ +30 6906 822402
- ✉ info.gr@wsl-refrigeration.com

West Europe

- 📍 West Europe
- ☎ +386 1 244 08 00
- ✉ info.si@wsl-refrigeration.com

Central and East Europe

- 📍 Central and East Europe
- ☎ +48 690 654 054
- ✉ info.cee@wsl-refrigeration.com

Balkan

- 📍 Balkan
- ☎ +381 64 64 10 439
- ✉ info.balkan@wsl-refrigeration.com

Middle East

- 📍 Middle East
- ☎ +381 64 64 41 850
- ✉ info.middleeast@wsl-refrigeration.com

America

- 📍 America
- ☎ +386 1 244 08 00
- ✉ info.si@wsl-refrigeration.com

Africa

- 📍 Africa
- ☎ +381 22 2155 701
- ✉ info.rs@wsl-refrigeration.com

Asia

- 📍 Asia
- ☎ +381 22 2155 701
- ✉ info.rs@wsl-refrigeration.com