





# NEPTUN

## NEPTUN P&P

**NEPTUN P&P** is a full height vertical plug-in cabinet ideal for displaying a great variety of frozen foods. Condensation unit below the cabinet is very low and occupies an extremely small space, which increases the total display area of NEPTUN P&P cabinets. The condensate unit is installed in a pull-out drawer, which enables **easy access for maintenance**.

**LED illuminated cabinet** provides great visibility of displayed products and enhances their visual appearance. Due to implemented natural refrigerant R290 NEPTUN P&P is operating quietly and leaves a smaller footprint on the environment.

**Temperature class:** L1

**Refrigerant:** R290

This cabinet is available in two height versions with an option of anti-fog doors without heaters in glass. **Vertical**

### LOW TEMPERATURE CABINET

- Available in SKY (S) and Horizon (H) design line NEPTUN S P&P
- NETPUN S P&P cabinets have unified design, base and bumper height, aligned with cabinets SKY P&P and COMET P&P S, perfect for side by side placement, generating a harmonized and engaging refrigeration line.

### CUSTOMIZATION

- Controller options (Danfoss, Carel, Dixell, Wurm, Eliwell)
- Vertical LED lightning (colour adapted to food group)
- High efficiency EC fans
- Stainless steel bumper
- PVC bumper
- Endwalls - blind, panoramic, intermediate
- A variety of interior / exterior colour options

Accessories: Base grid, base and shelf dividers, plexi full height dividers, etc.

**STANDARD EQUIPMENT**

- Vertical LED lightning



NEPTUN P&P

**NEPTUN S P&P:**

- Energy free anti-fog coated doors
- Glass top canopy
- High efficiency EC fans

**NEPTUN H P&P:**

- Triple glass high efficiency doors - low energy consumption
- Metal top canopy - a variety of color options available

NEPTUN S P&P

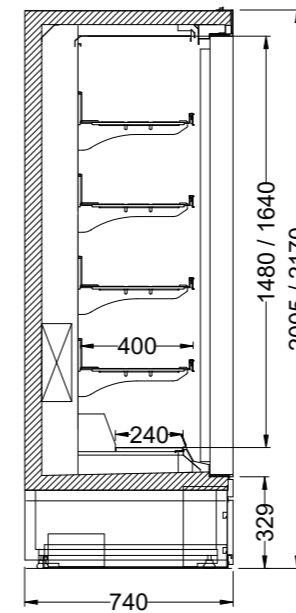

NEPTUN H P&P

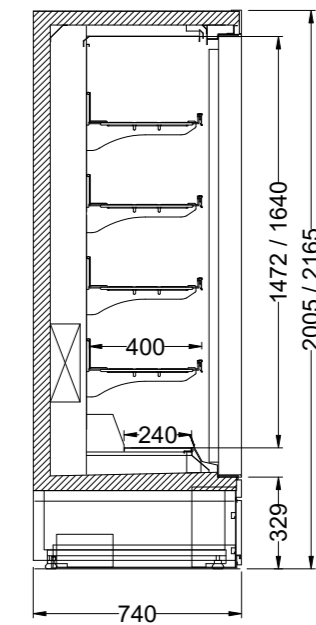

Design	Height (mm)	Vizual display (mm)	Depth (mm)	Shelf depth (mm)	Lenght (mm)			Temperature class*
					1562	2342	784	
S	2015	1480	740	400	✓	✓	✓	✓
	2170	1640	740	400	✓	✓	✓	
H	2005	1472	740	400	✓	✓	✓	
	2170	1640	740	400	✓	✓	✓	





**WE BRING FRESHNESS TO YOUR STORE**

**WSI** Refrigeration

**Germany / Austria /  
Switzerland**

- 📍 Germany / Austria /  
Switzerland
- ☎ +49 1525 54 29 168
- ✉ info.de@wsl-refrigeration.de

**Slovenia / BIH /  
Montenegro**

- 📍 Sneberska cesta 111B  
1260 Ljubljana-Polje
- ☎ +386 1 244 08 00
- ✉ info.si@wsl-refrigeration.com

**Serbia**

- 📍 Prva severna 8  
22300 Stara Pazova
- ☎ +381 22 2155 701
- ✉ info.rs@wsl-refrigeration.com

**Croatia**

- 📍 Zagrebačka cesta 233  
10000 Zagreb
- ☎ +385 1 3882 668
- ✉ info.hr@wsl-refrigeration.com

**Greece**

- 📍 Greece
- ☎ +30 6906 822402
- ✉ info.gr@wsl-refrigeration.com

**West Europe**

- 📍 West Europe
- ☎ +386 1 244 08 00
- ✉ info.si@wsl-refrigeration.com

**Central and East Europe**

- 📍 Central and East Europe
- ☎ +48 690 654 054
- ✉ info.cee@wsl-refrigeration.com

**Balkan**

- 📍 Balkan
- ☎ +381 64 64 10 439
- ✉ info.balkan@wsl-refrigeration.com

**Middle East**

- 📍 Middle East
- ☎ +381 64 64 41 850
- ✉ info.middleeast@wsl-refrigeration.com

**America**

- 📍 America
- ☎ +386 1 244 08 00
- ✉ info.si@wsl-refrigeration.com

**Africa**

- 📍 Africa
- ☎ +381 22 2155 701
- ✉ info.rs@wsl-refrigeration.com

**Asia**

- 📍 Asia
- ☎ +381 22 2155 701
- ✉ info.rs@wsl-refrigeration.com